



DESCRIPTION

The A2211 is a mono fully-differential audio power amplifier designed for portable communication device applications.

The A2211 operates from 2.2V to 5.5V, is capable of delivering 1.25W of continuous average power to an 8Ω BTL load with less than 1% distortion (THD+N) from a 5V supply.

A2211 features like -86dB PSRR at 217Hz, improved RF-rectification immunity, small PCB area, a fast startup with minimal pop & click circuitry makes the A2211 idea for PDA, smartphone applications; and low power shutdown mode suitable for wireless handsets.

The A2211 is unity-gain stable, and the gain can be configured by external input resistors and internal feedback resistors.

The A2211 is available in MSOP8 package

ORDERING INFORMATION

Package Type	Part Number	
MSOP8 SPQ: 4,000pcs/Reel	MS8	A2211MS8R
		A2211MS8VR
Note	V: Halogen free Package R: Tape & Reel	
AiT provides all RoHS products		

FEATURES

- 1.25W into 8Ω from a 5V Supply at THD=1% (Typ)
- Wide Supply Voltage: 2.2V to 5.5V
- Ultra low shutdown current: 0.01uA (Typ)
- Fast Startup With Minimal POP
- Fully differential design reduce RF rectification
- Improved PSRR -86dB at 217Hz ($V_{DD}>3.0V$)
- Improved pop & click circuitry eliminates Noise During Turn-on and Turn-off Transitions
- Thermal overload protection circuitry
- No output coupling capacitors, bootstrap capacitors required
- Unity-gain stable
- External gain configuration capability
- Available in MSOP8 package

APPLICATION

- GPS, Wireless Handsets
- Portable Audio Devices
- PDA, Handheld Computer
- RF Audio Application

TYPICAL APPLICATION

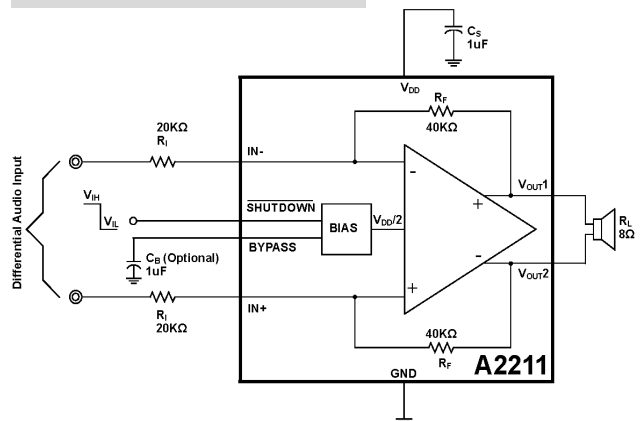



PIN DESCRIPTION

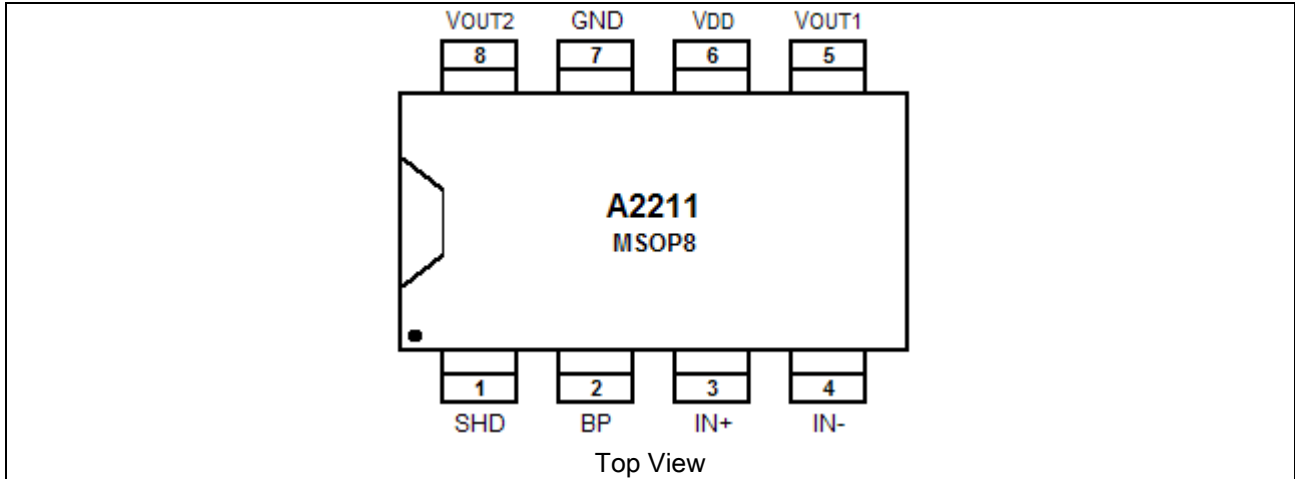

Pin #	Symbol	Type	Functions
1	SHD	I	Shutdown Pin, Active Low
2	BP	I	Common Mode Voltage. Connect a Bypass Capacitor to GND for Common Mode Voltage Filtering. The Bypass Capacitor is Optional.
3	IN+	I	Positive Differential Input
4	IN-	I	Negative Differential Input
5	V _{OUT1}	O	Positive Differential Output
6	V _{DD}	I	Power Supply
7	GND	I	Ground
8	V _{OUT2}	O	Negative Differential Output



ABSOLUTE MAXIMUM RATINGS

V _{DD} , Supply Voltage	-0.3V~+6.0V
Input Voltage	-0.3V~V _{DD} +0.3V
Power Dissipation ^{NOTE1}	Internally Limited
ESD Parameter	
ESD Protection (HBM, 1.5kΩ and 100pF in Series)	2000V
ESD Protection (MM, 200pF, no Resistor)	200V
θ _{JA} , Thermal Resistance	190°C/W
θ _{JC} , Thermal Resistance	56°C/W
T _J , Junction Temperature	-40°C ~+150°C
T _A , Environment Temperature	140°C
T _s , Storage Temperature Range	-65°C ~150°C
Lead Temperature (soldering, 10 seconds)	300°C

Stresses above may cause permanent damage to the device. These are stress ratings only, and functional operation of the device at these or any other conditions beyond those indicated in the Electrical Characteristics is not implied. Exposure to absolute maximum rating conditions for extended periods may affect device reliability.

NOTE1: The Maximum Power Dissipation must be de-rated at elevated temperatures and is dictated by T_{JMAX}, θ_{JA}, and the ambient temperature T_A. The maximum allowable power dissipation is: P_{DMAX} = (T_{JMAX} - T_A) / θ_{JA} or the number given in Absolute Maximum Ratings, whatever is lower.

OPERATING CONDITIONS

Parameter	Symbol	Min	Typ	Max	Unit
Power Supply Voltage	V _{DD}	2.2	-	5.5	V
Operating Temperature Range	T _A	-40	-	85	°C



ELECTRICAL CHARACTERISTICS

Test Condition: 1. $V_{DD}=5V$, 8Ω load, $A_v=1V/V$, $T_A=25^\circ C$, unless otherwise noted.

Symbol	Parameter	Conditions	Min.	Typ.	Max.	Unit
I _{DD}	Quiescent Power Supply Current	V _{IN} =0V, no Load	-	2.5	5	mA
		V _{IN} =0V, R _L =8Ω	-	4	8	
I _{SD}	Shutdown Current	V _{SHUTDOWN} =GND	-	0.01	1	μA
P _o	Output Power	THD+N=1%, f=1kHz	-	1.25	-	W
THD+N	Total Harmonic Distortion +Noise	Po=0.6Wrms, f=1kHz	-	0.02	-	%
PSRR	Power Supply Rejection Ratio	V _{RIPPLE} =200mV sine p-p				dB
		f=217Hz ^{NOTE1}	-	-88	-	
		f=1kHz ^{NOTE1}	-	-83	-	
		f=217Hz ^{NOTE2}	-	-83	-	
		f=1kHz ^{NOTE2}	-	-83	-	
CMRR	Common Mode Rejection Ratio	f=217Hz V _{CM} =200mVpp	-	-78	-	dB
V _{OS}	Output Offset	V _{IN} =0V	-	2	8	mV
V _{SDIH}	Shutdown Voltage Input High		1.5	-	-	V
V _{SDIL}	Shutdown Voltage Input Low		-	-	0.5	V
A _v	Closed Loop Gain		$\frac{36k\Omega}{R_i}$	$\frac{40k\Omega}{R_i}$	$\frac{44k\Omega}{R_i}$	V / V

Test Condition: 2. $V_{DD}=3.6V$, 8Ω load, $A_v=1V/V$, $T_A=25^\circ C$, unless otherwise noted.

Symbol	Parameter	Conditions	Min.	Typ.	Max.	Unit
I _{DD}	Quiescent Power Supply Current	V _{IN} =0V, no Load	-	2	4.5	mA
		V _{IN} =0V, R _L =8Ω	-	3.5	7.5	
I _{SD}	Shutdown Current	V _{SHUTDOWN} =GND	-	0.01	1	μA
P _o	Output Power	THD+N=1%, f=1kHz	-	0.6	-	W
THD+N	Total Harmonic Distortion +Noise	Po=0.4Wrms, f=1kHz	-	0.02	-	%
PSRR	Power Supply Rejection Ratio	V _{RIPPLE} =200mV sine p-p				dB
		f=217Hz ^{NOTE1}	-	-86	-	
		f=1kHz ^{NOTE1}	-	-83	-	
		f=217Hz ^{NOTE2}	-	-83	-	
		f=1kHz ^{NOTE2}	-	-83	-	
CMRR	Common Mode Rejection Ratio	f=217Hz, V _{CM} =200mVpp	-	-76	-	dB
V _{OS}	Output Offset	V _{IN} =0V	-	2	8	mV
V _{SDIH}	Shutdown Voltage Input High		1.5	-	-	V
V _{SDIL}	Shutdown Voltage Input Low		-	-	0.5	V
Gain	Closed Loop Gain		$\frac{36k\Omega}{R_i}$	$\frac{40k\Omega}{R_i}$	$\frac{44k\Omega}{R_i}$	V / V

NOTE 1: Unterminated Input

NOTE 2: 10Ω Terminated Input



TYPICAL PERFORMANCE CHARACTERISTICS

1. Output Power vs. Supply Voltage, $R_L=8\Omega$

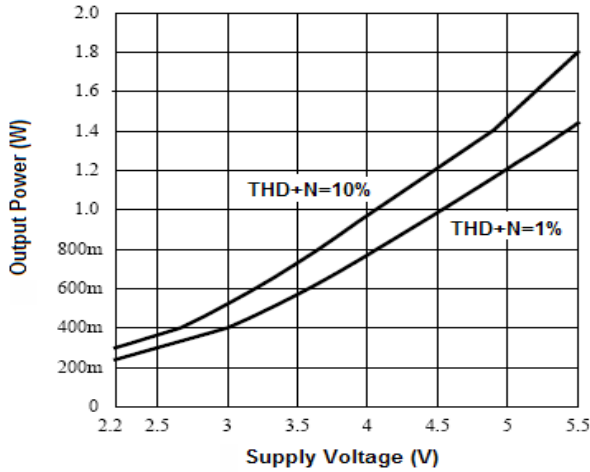

2. Power Dissipation vs. Output Power

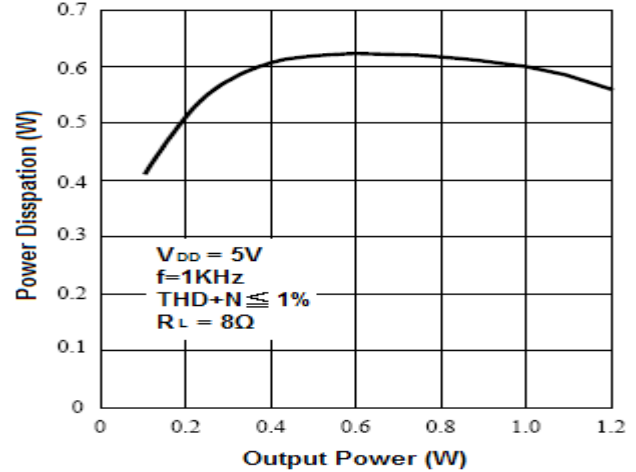

3. Power Dissipation vs. Output Power

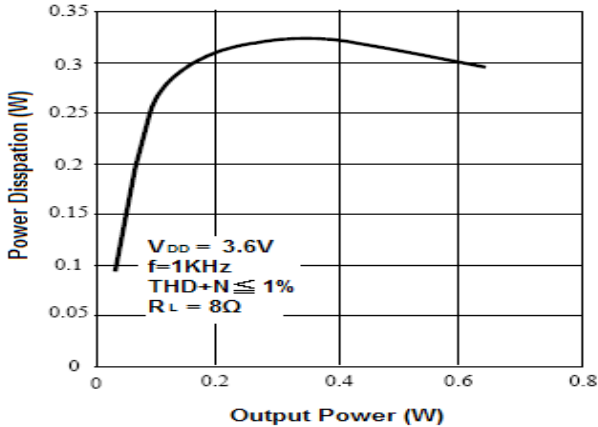

4. Power Derating Curve

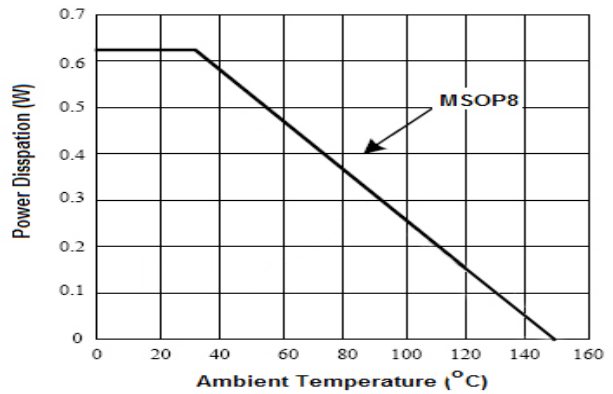

5. THD+N vs. Frequency

$V_{DD}=5V$, $R_L=8\Omega$, $P_o=600mW$

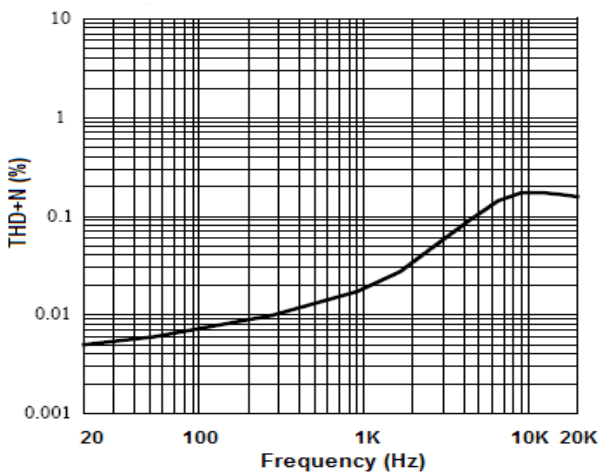

6. THD+N vs. Frequency

$V_{DD}=3.6V$, $R_L=8\Omega$, $P_o=400mW$

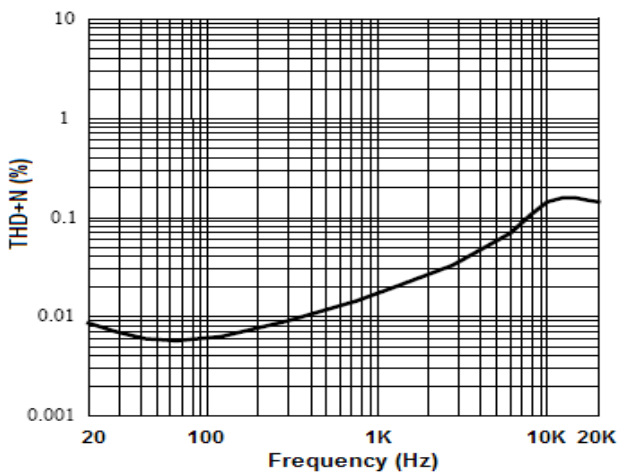



7. THD+N vs. Frequency

$V_{DD}=2.5V$, $R_L=8\Omega$, $P_o=150mW$

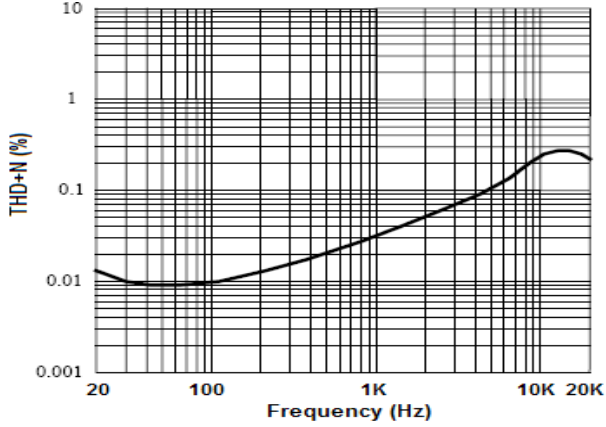

8. THD+N vs. Output Power

$V_{DD}=5V$, $R_L=8\Omega$

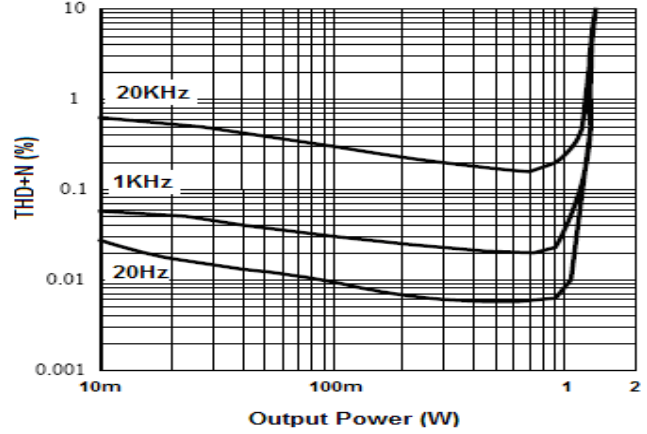

9. THD+N vs. Output Power

$V_{DD}=3.6V$, $R_L=8\Omega$

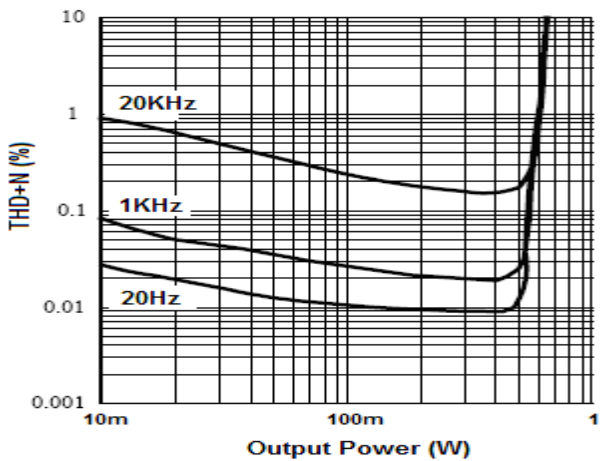

10. THD+N vs. Output Power

$V_{DD}=2.5V$, $R_L=8\Omega$

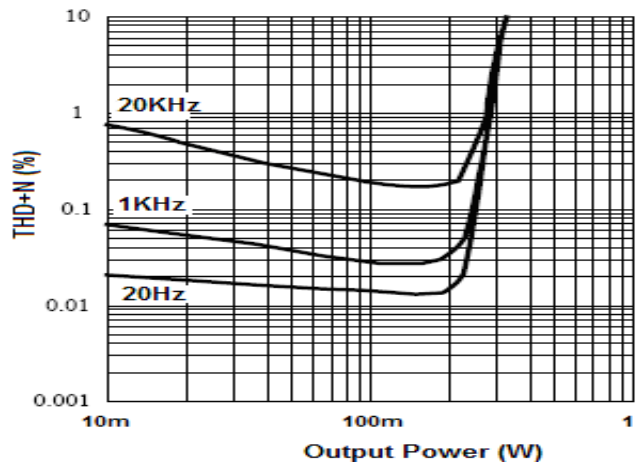

11. PSRR vs. Frequency

$V_{DD}=5.0V$, $R_L=8\Omega$, Input 10Ω Terminated

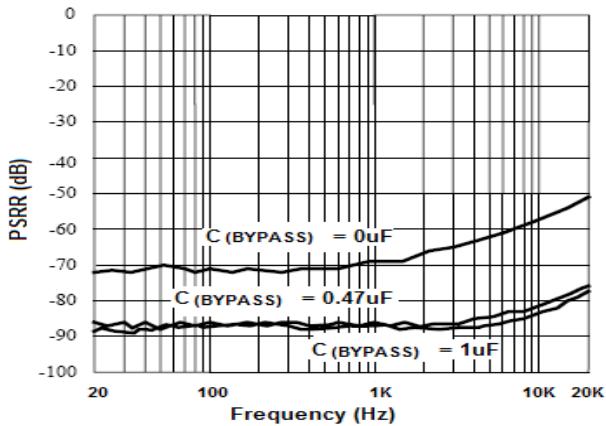

12. PSRR vs. Frequency

$V_{DD}=3.6V$, $R_L=8\Omega$, Input 10Ω Terminated

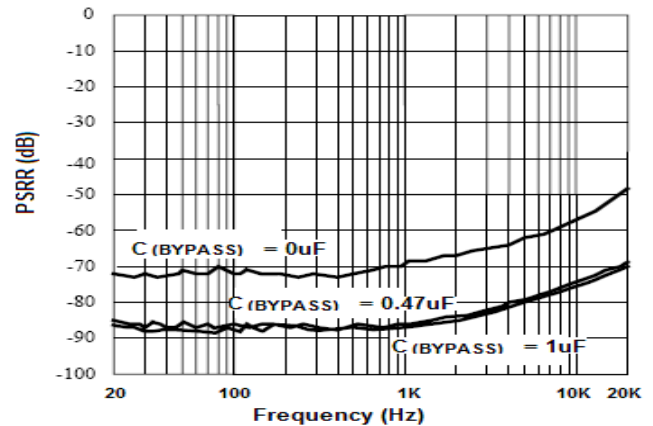



13. PSRR vs. Common Mode Voltage
 $V_{DD}=5.0V$, $R_L=8\Omega$, 217Hz, 200mV_{PP}

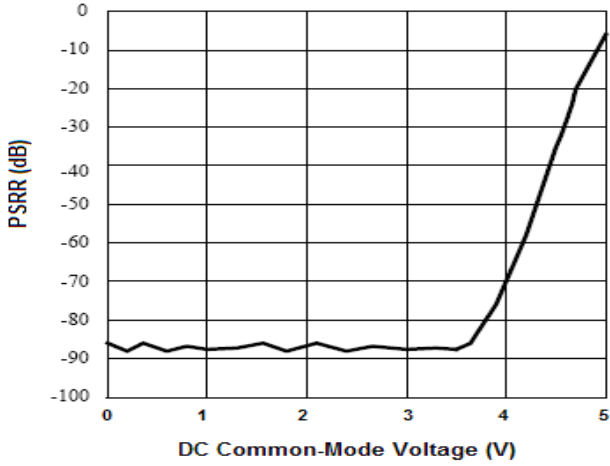

14. PSRR vs. Common Mode Voltage
 $V_{DD}=3.6V$, $R_L=8\Omega$, 217Hz, 200mV_{PP}

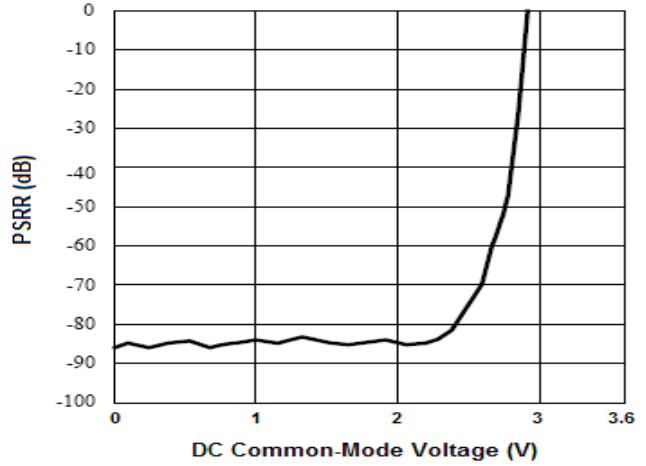

15. Open Loop Frequency Response

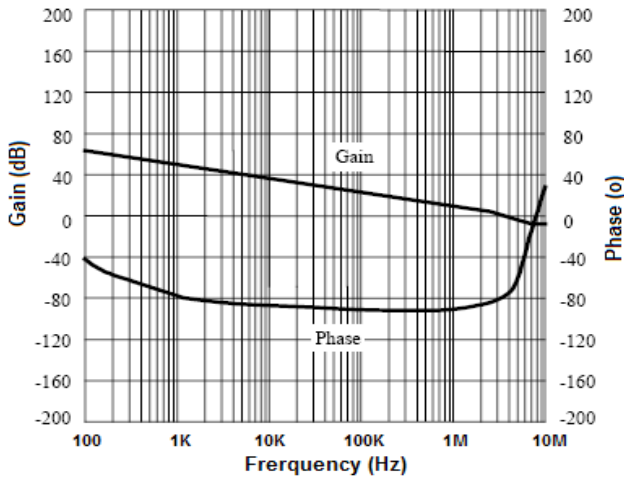

16. Closed Loop Frequency Response

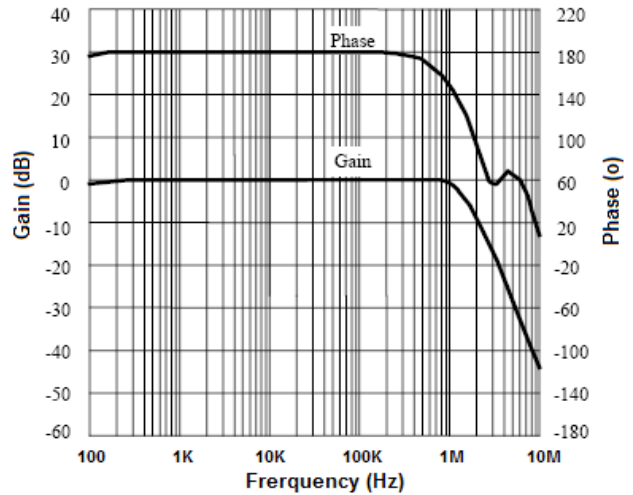



BLOCK DIAGRAM

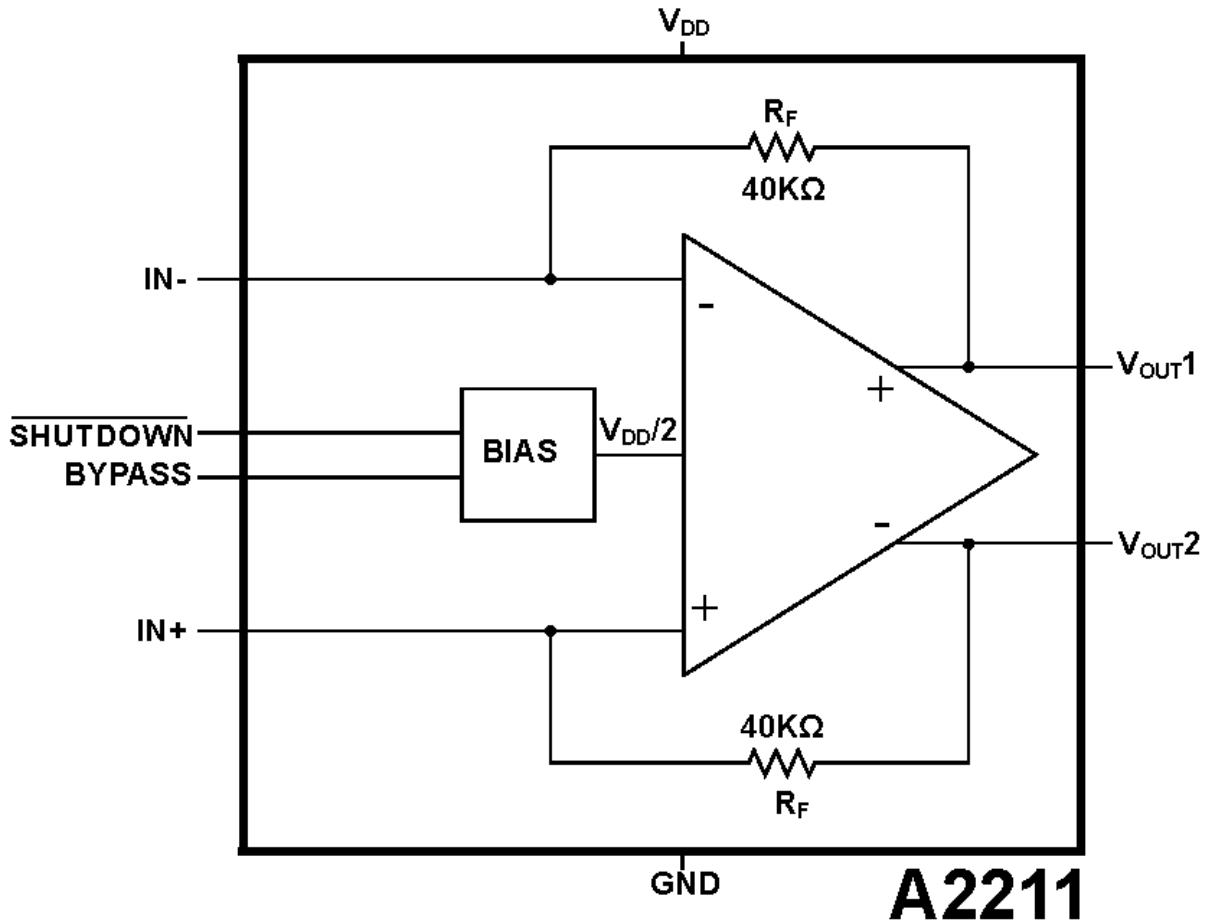



DETAILED INFORMATION

Fully Differential Amplifier. The A2211 is a fully differential amplifier with differential inputs and outputs. The fully differential amplifier consists of a differential amplifier and a common mode amplifier. The differential amplifier ensures that the amplifier outputs a differential voltage that is equal to the differential input times the gain. The common mode feedback ensures that the common-mode voltage at the output is biased around $V_{DD}/2$ regardless of the common-mode voltage at the input.

Bridge – Tied - Load, BTL. The A2211 provides a “bridged mode” output configuration (bridge-tied-load, BTL). This means the output signals at V_{OUT1} and V_{OUT2} that at 180°C out of phase with respect to each other. Bridged mode operation is different from the single-ended output configuration that connects the load between the amplifier output and ground. A bridged amplifier design has distinct advantages over the single-ended output configuration: A2211 provides differential drive to the load, thus doubling maximum possible output swing for a specific supply voltage. Four times the output power is possible compared with a single-ended output configuration under the same conditions. This increase in attainable output power assumes that the amplifier is not current limited or clipped.

CMRR. Input and output coupling capacitor not required: A fully differential amplifier with good CMRR, the A2211 allows the input signal to be biased at voltage other than mid-supply of the A2211, the common-mode feedback circuit adjust for it, and the outputs are still biased at mid-supply of the A2211.

Bypass Capacitor. Mid-supply bypass capacitor, C_{BYPASS} not required: The fully differential amplifier does not require a bypass capacitor. It is because any shift in the mid-supply affects both positive and negative channels equally and cancels the differential output. However, removing the bypass capacitor slightly worsens power supply rejection ration, but a slightly decrease of PSRR may be acceptable when an additional component can be eliminated.

Better RF-Immunity. GSM handsets save power by turning on and shutting off the RF transmitter at a rate of 217Hz. The transmitted signal is picked-up on input and output traces. The fully differential amplifier reduces the RF rectification much better than the typical audio amplifier.

See Fig 1, Fig 2 and Fig 3 show application schematics for differential and single-ended inputs.

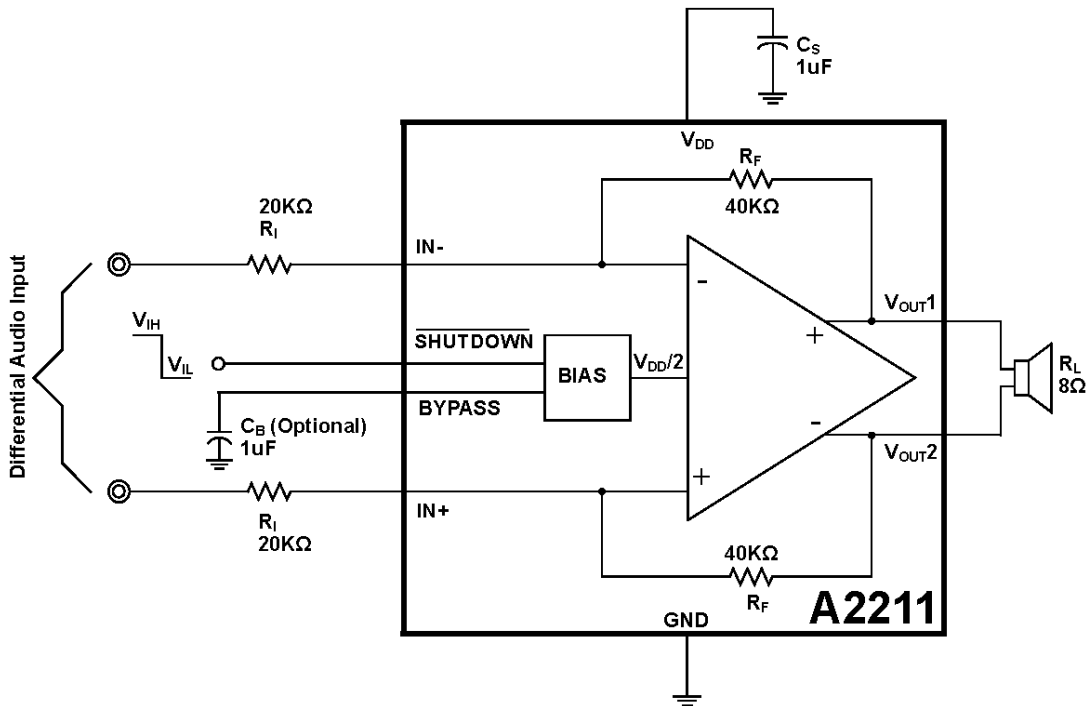

Fig. 1 Typical Differential Input Application

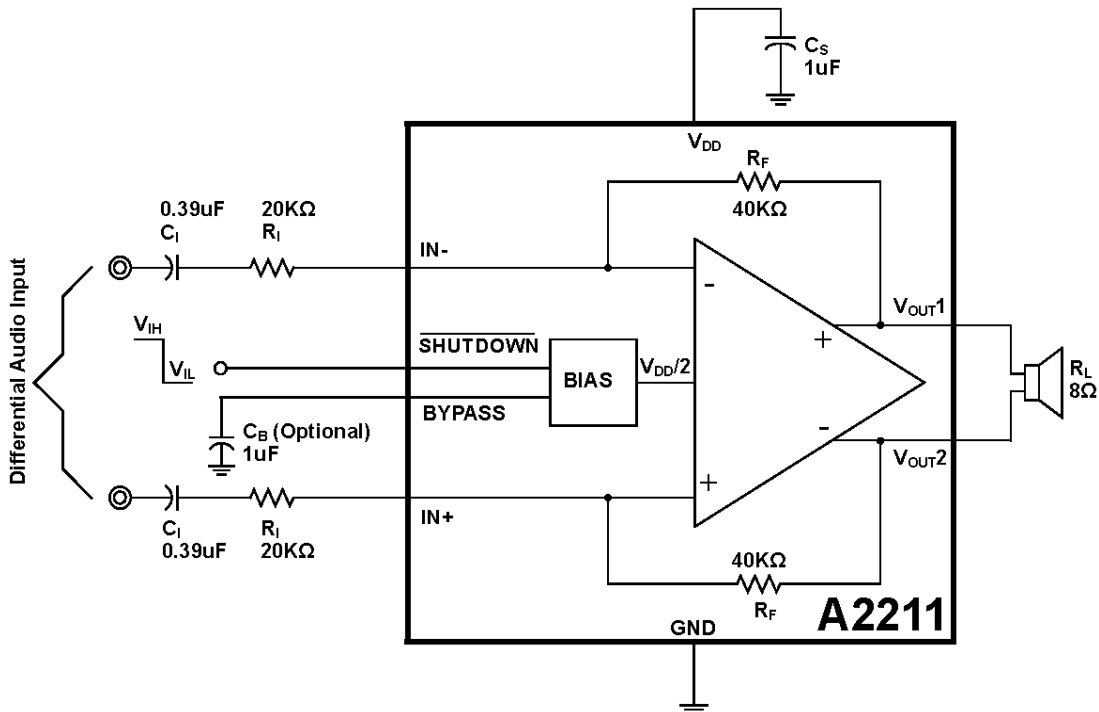

Fig. 2 Differential Input Application with Input Capacitors

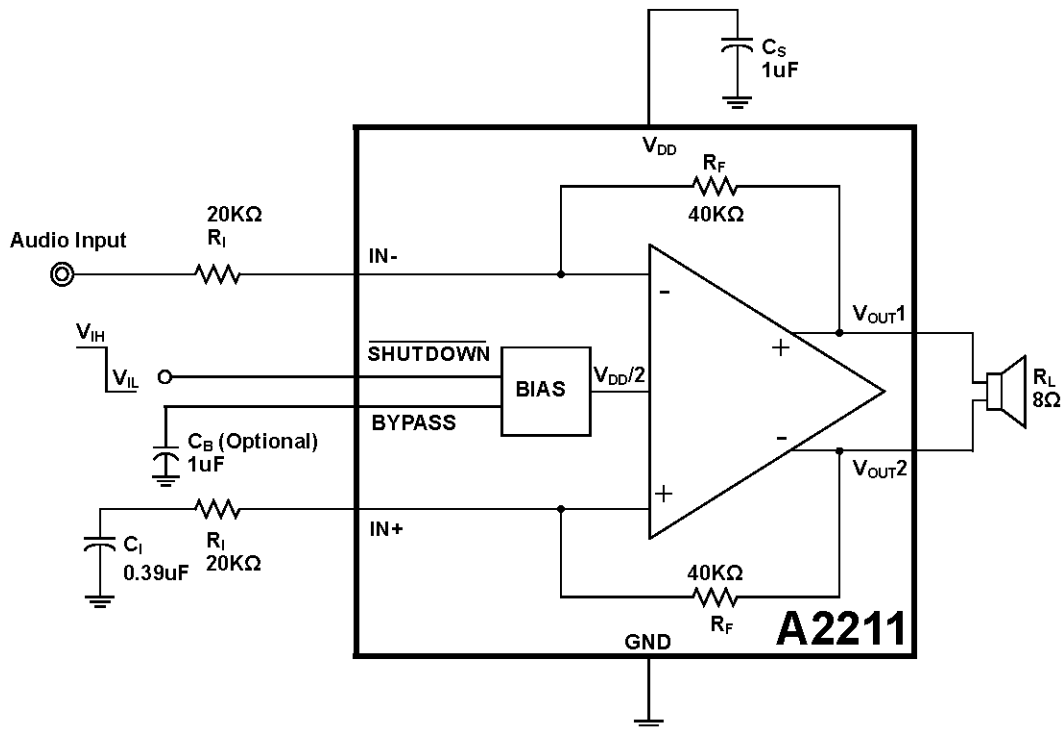

Fig. 3 Single-Ended Input Application

Input Resistor (R_i)

The input (R_i) and internal feedback resistors, R_F=40kΩ, set the gain of the amplifier according to the following (E1):

$$\text{Gain} = 40\text{k}\Omega / R_i$$

In order to optimize the THD+N and SNR performance, the A2211 should be used in low closed-loop gain configuration. R_i should be in range from 1kΩ to 100kΩ. Resistor matching is very important for fully differential amplifiers. The balance of the output on the common mode voltage depends on matched ratios of the resistors. CMRR, PSRR, and the second harmonic distortion is increased if resistor is not matched. Therefore, it is recommended to use 1% tolerance resistors or better to keep the performance optimized.



Input Capacitor (C_i)

The input coupling capacitor blocks the input DC voltage. The A2211 does not require input coupling capacitors if using a differential input source that is biased from 0.5V to $V_{DD}-0.8V$. Use 1% tolerance or better resistors if not using input coupling capacitors. In the single-ended input application an input capacitor, C_i , is required to allow the amplifier to bias the input signal to the proper DC level.

The C_i and R_i from a high-pass filter with the corner frequency determined as below (E2):

$$f_c = 1 / 2\pi R_i C_i$$

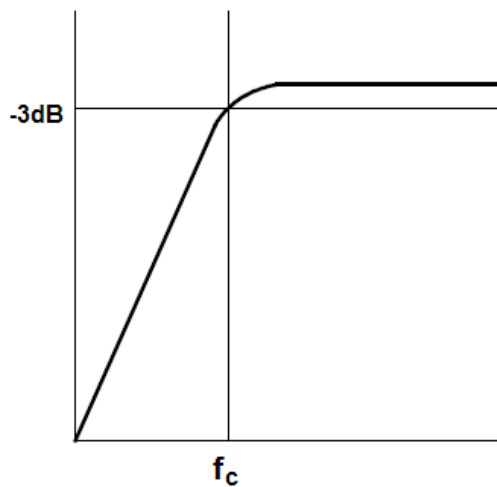

Special care should be taken to the value of the value of C_i because it directly affects the low frequency performance of the system. For example assuming R_i is 20k Ω and the specification calls for a flat response down to 100Hz. From above, C_i is 0.08 μF , so C_i would likely choose a value in the range of 0.068 μF to 0.47 μF . A further consideration for C_i is the leakage path from the input source through the input network (R_i , C_i) and the feedback resistor (R_F) to the load. The leakage current creates a DC offset voltage that reduces useful headroom, especially in high gain applications. For this reason, a ceramic capacitor is the best choice.

Bypass capacitor (C_B) and Start-Up Time

Connecting a capacitor to BP pin filters any noise into this pin and increases the PSRR performance. C_B also determines the rise time of V_{OUT1} and V_{OUT2} , the larger the capacitor, the slower the rise time, the A2211 start to work after the C_B voltage reaches the mid-supply voltage. This capacitor can also minimize the pop & click noise during turn-on and turn-off transitions, the larger the capacitor, the smaller the pop & click noise, 1 μF capacitor is recommended for C_B .



Decoupling Capacitor (Cs)

Power supply decoupling is critical for low THD+N and high PSRR performance. A low equivalent-series-resistance (ESR) ceramic capacitor, typically 0.1uF to 1uF, placed as close as possible to V_{DD} pin make the device works better. For filtering lower frequency noise signals, a 10uF or greater capacitor placed near the audio power amplifier also helps, but it is not required in most applications because of the high PSRR of this device.

LOW-ESR Capacitors

LOW-ESR capacitors are recommended. A real capacitor can be modeled simply as a resistor in series with an ideal capacitor. The voltage drop across this resistor minimizes the beneficial effects of the capacitor in the circuit. The lower the equivalent value of this resistance the more the real capacitor behaves like an ideal capacitor.

Power Dissipation

Power dissipation is a major concern when designing a successful amplifier, whether the amplifier is bridged or single-ended. Below (E3) states, the maximum power dissipation point for a single-ended amplifier operating at a given supply voltage and driving a specified output load.

Single-Ended (E3):

$$P_{\text{DMAX}} = (V_{\text{DD}})^2 / (2\pi^2 R_L)$$

However, a direct consequence of the increased power delivered to the load by a bridge amplifier is an increase in internal power dissipation versus a single-ended amplifier operating at the same conditions.

Bridge-Ended (E4):

$$P_{\text{DMAX}} = 4 \times (V_{\text{DD}})^2 / (2\pi^2 R_L)$$

Since the A2211 has bridged outputs, the maximum internal power dissipation is 4 times that of a single-ended amplifier. Even with this substantial increasing in power dissipation, the A2211 does not require additional heat-sinking under most operating conditions and output loading. From the above (E4), assuming a 5V power supply and an 8Ω load, the maximum power dissipation point is 625mW. The maximum power dissipation point obtained from above (E4) must not be greater than the power dissipation results from the follows (E5):

$$P_{\text{DMAX}} = (T_{\text{JMAX}} - T_{\text{A}}) / \theta_{\text{JA}}$$

Depending on the ambient temperature (T_A) of the system surroundings, above can be used to find the



maximum internal power dissipation supported by the IC packaging. If the result of Bridge-Ended (E4) is greater than that of (E5), then either the supply voltage must be decreased, the load impedance increased, the ambient temperature reduced, or the θ_{JA} reduced with heat-sinking. In many cases, larger traces near the output, V_{DD} , and GND pins can be used to lower the θ_{JA} . The larger areas of copper provide a form of heat-sinking allowing higher power dissipation. Recall that internal power dissipation is a function of output power. If the typical operation is not around the maximum power dissipation point, the A2211 can operate at higher ambient temperatures.

Shutdown Function

The A2211 contains shutdown circuitry that is used to turn off the amplifier's bias circuitry, in order to reduce power consumption while not in use. The shutdown pin should be tied to a definite voltage to avoid unwanted state changes. In many applications, a microcontroller or microprocessor output is used to control the shutdown circuitry, which provides a quick, smooth transition to shutdown. Another solution is to use a single-throw switch in conjunction with an external pull-down resistor. This scheme guarantees that the shutdown pin will not float, thus preventing unwanted state changes.

PCB Layout

The residual resistance of the PCB trace between the amplifier output pins and the speaker causes a voltage drop, which results in power dissipated in the PCB trace and not in the speaker as desired. Therefore, to maintain the highest speaker power dissipation and widest output voltage swing, PCB trace that connects the amplifier output pins to the speaker must be as wide as possible.

Poor power supply regulation adversely affects maximum output power. A poorly regulated supply's output voltage decreases with increasing load current. Reduced supply voltage causes decrease headroom, output signal clipping, and reduced output power. Even with tightly regulated supplies, power supply trace resistance creates the same effects as poor supply regulation. Therefore, be making the power supply trace as wide as possible helps to maintain full output voltage swing.

It's very important to keep the A2211 external components very close to the A2211 to limit noise pickup.



PACKAGE INFORMATION

Dimension in MSOP8 (Unit: mm)

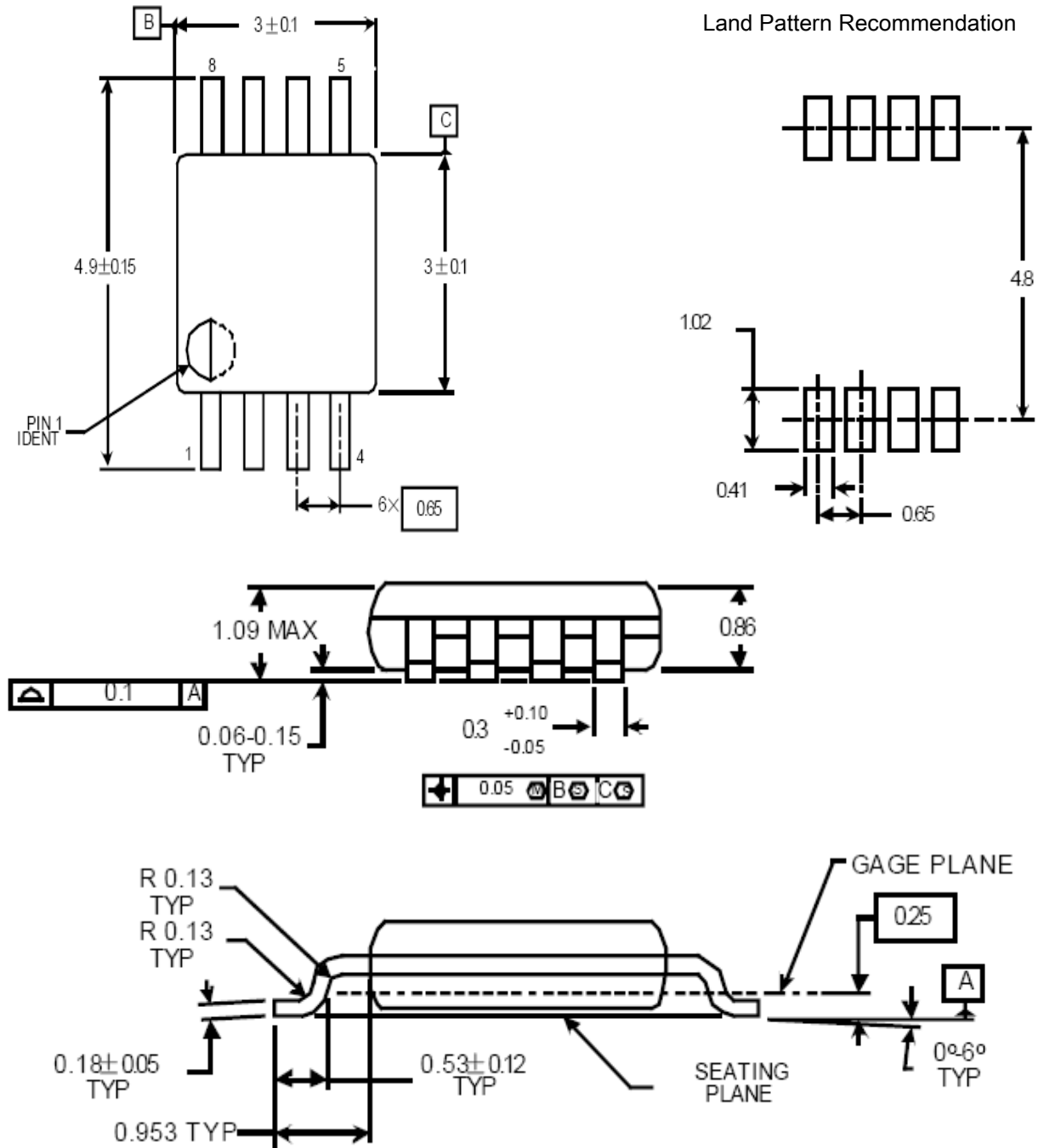



IMPORTANT NOTICE

AiT Semiconductor Inc. (AiT) reserves the right to make changes to any its product, specifications, to discontinue any integrated circuit product or service without notice, and advises its customers to obtain the latest version of relevant information to verify, before placing orders, that the information being relied on is current.

AiT Semiconductor Inc.'s integrated circuit products are not designed, intended, authorized, or warranted to be suitable for use in life support applications, devices or systems or other critical applications. Use of AiT products in such applications is understood to be fully at the risk of the customer. As used herein may involve potential risks of death, personal injury, or severe property, or environmental damage. In order to minimize risks associated with the customer's applications, the customer should provide adequate design and operating safeguards.

AiT Semiconductor Inc. assumes to no liability to customer product design or application support. AiT warrants the performance of its products of the specifications applicable at the time of sale.